

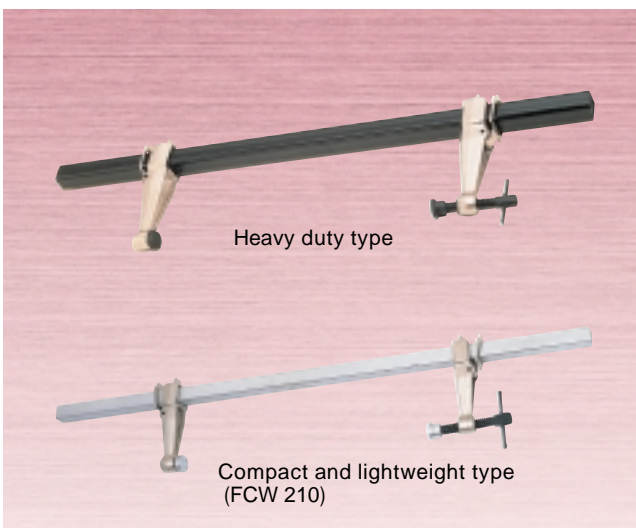

SUPER SETTER PAT.

FCW 210~420



Easy and flexible for temporary stabilizing of welded, steel structures, bridges and civil engineering work.
 Optimal for assembling temporary structures and framing at civil engineering and construction sites.
 Optimal for tightening and holding work, and also for expanding and supporting work.

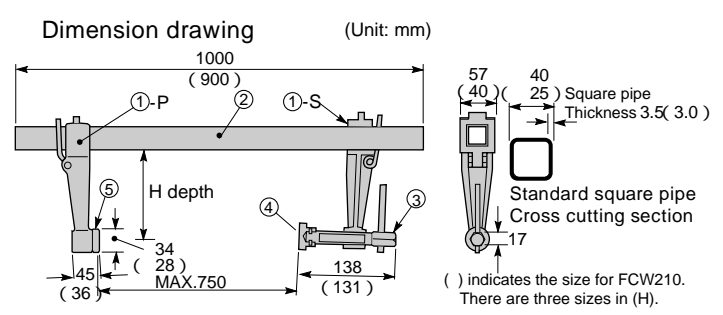

Capacity

Item No.	Clamping range	Depth(H dimension)	Set weight (Standard square pipe only)	Permissible loads (K.N)	Remarks
FCW 210	0 ~ 700mm	100mm	3.3kg (1.9kg)	3.5 (at the clamping range of 700mm)	
FCW 410	0 ~ 750mm	100mm	6.3kg (3.9kg)	5.5 (at the clamping range of 750mm)	
FCW 415	0 ~ 750mm	150mm	6.9kg (3.9kg)	3.9 (at the clamping range of 750mm)	
FCW 420	0 ~ 750mm	200mm	7.5kg (3.9kg)	3.0 (at the clamping range of 750mm)	

Parts No. (Standard parts are provided in a set.)

Name·Drawing No.	Body-S (with forcing screw, adapter and handle)	Body-P (with fixing screw)	Standard square pipe (0.9m) (1m)	Forcing screw (with handle)	Adapter for forcing screw (with spring)	Fixing screw
Item No.	-S	-P				
FCW 210	FCWS 210	FCWP 210	FCWK 210	FCWD 210	FCWH 210	FCWU 210
FCW 410	FCWS 410	FCWP 410	FCWK 40	FCWD 40	FCWH 40	FCWU 40
FCW 415	FCWS 415	FCWP 415	FCWK 40	FCWD 40	FCWH 40	FCWU 40
FCW 420	FCWS 420	FCWP 420	FCWK 40	FCWD 40	FCWH 40	FCWU 40

Examples of use

Optimal for expanding and tightening a variety of work.

