

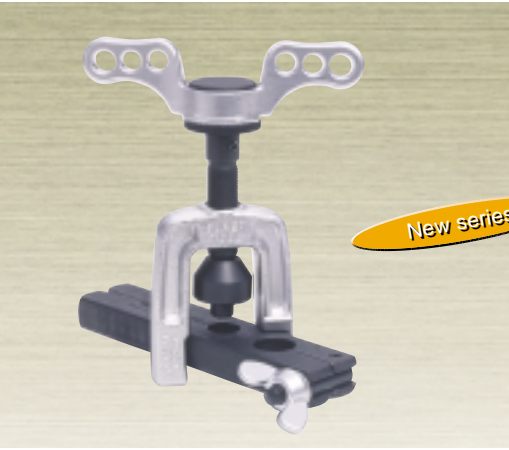

FLANGING TOOL for Flexible tube (Switching plate type) PAT.P.



New series

TH 1320R

Easy work by ratchet mechanism.
Easy to flanging 2 or 3 ridges, and complete perfectly.



Item No.	Tube fixing capacity	Weight (kg)	Remarks
TH 1320R	Stainless steel flexible tube for water 1/2 (13mm)・3/4 (20mm)	1.1	

FLANGING TOOL for Flexible tube (Ratchet type) PAT.



TH 406R

One flanging tool can handle 2 sizes of flexible tube.
The ratchet handle enables speedy operation.
Possible for flanging 2 or 3 ridges.
The flanging side is evenly and cleanly finished.
Possible to use flexible tubes of a variety of manufacturers (Some flexible tubes do not apply due to shape and size.)

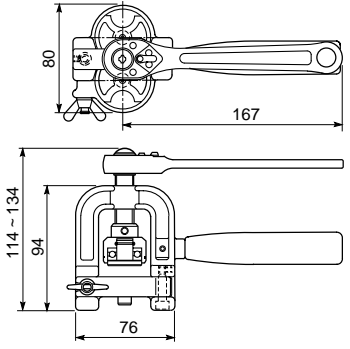

Item No.	Applicable tube (External diameter)	Weight (g)	Remarks
TH 406R	Stainless steel flexible tube for water (Single corrugate pipe) 1/2 (13mm)、3/4 (20mm)	1,480	

Operation procedure

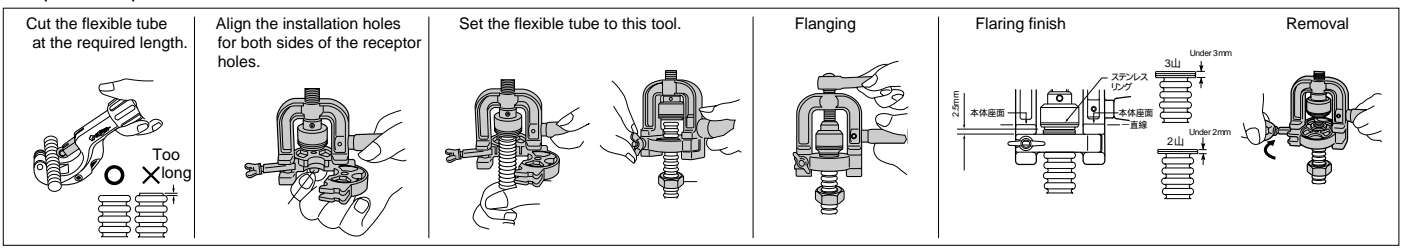

FLANGING · CUTTER SET for Flexible tube



THS 406R

Plastic case supplied.
Cutting (Flexible pipe cutter) and flanging tool set.

Item No.	Set contents	Set weight (g)	Remarks
THS 406R	Flanging tool (TH 406R) Flexible pipe cutter (TC 105F)	2,2	

FLANGING TOOL for Flexible tube (Feeding handle type)



TH 1320

The flanging of flexible pipe is easy, reliable and even.
The feeding handle type enables easy and efficient operation.
Possible for flanging 2 or 3 ridges.

Item No.	Applicable tube (External diameter)	Weight (g)	Remarks
TH 1320	Stainless steel flexible tube for water 1/2 (13mm), 3/4 (20mm) 1/2 (13mm) ・ 3/4 (20mm)	990	