

## UNI- CLAMP (Flexible type)

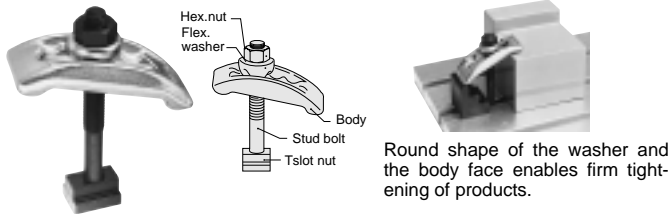

Item No.	Set contents					Set weight (kg)
	Hex.nut	Body and flex.washer	Stud bolt	T-slot nut		
FT 10	FTU 10	FTBZ 10	FTN 10100	FTS 1012		0.27
FT 12	FTU 12	FTBZ 12	FTN 12125	FTS 1214		0.50
FT 14	FTU 14	FTBZ 14	FTN 14150	FTS 1416		0.86
FT 16	FTU 16	FTBZ 16	FTN 16150	FTS 1618		0.93
FT 18	FTU 18	FTBZ 18	FTN 18175	FTS 1820		1.92
FT 20	FTU 20	FTBZ 20	FTN 20180	FTS 2022		2.05
FT 22	FTU 22	FTBZ 22	FTN 22200	FTS 2226		3.62
FT 24	FTU 24	FTBZ 24	FTN 24250	FTS 2428		4.02

## BODY and FLEX.WASHER

(Unit:mm)



Item No.	Applicable bolt	Set weight (kg)
FTBZ 10	M10	0.18
FTBZ 12	M12	0.35
FTBZ 14	M14	0.62
FTBZ 16	M14 · M16	0.61
FTBZ 18	M18	1.43
FTBZ 20	M18 · M20	1.42
FTBZ 22	M22	2.78
FTBZ 24	M24	2.76
FTBZ 4.5	M14 · M16	0.33

## TWIN CLAMP

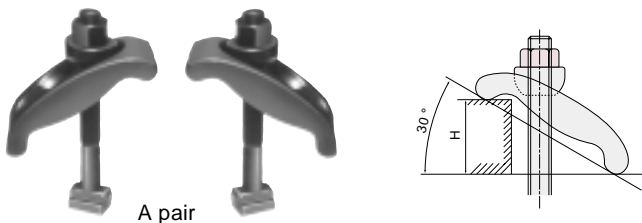

Secure clamping is available even if the main body is slanted sideways (max. 30 degrees).  
Washer is ball-shaped to fit in the main body.  
Washer (bolt) can be set at two positions, gaining four different dimensions from the end of the main body.  
The main body and washer are forged to be robust.

Item No.	Body	Flex.washer	Heavy nut	T-slot bolt	H	Weight (kg) (A pair)
TW 12	FQB 12	FQZ 12	12 MHN	TBM 12125	0 ~ 43	1.12
TW 16	FQB 16	FQZ 16	16 MHN	TBM 16150	0 ~ 53	2.22
TW 20	FQB 20	FQZ 20	20 MHN	TBM 20175	0 ~ 71	4.77

## U- CLAMP

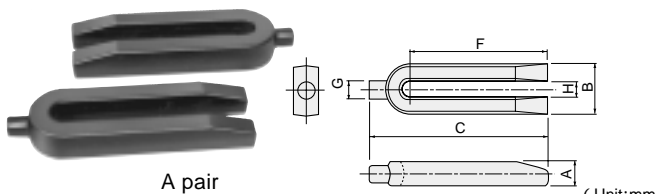

Item No.	A	B	C	F	G	H	Applicable bolt	Weight (kg) (A pair)
UC 4	19	45	114	77.5	14	17	M14·M16	0.78
UC 6	22	50	167	125	17	17	M16	1.50
UC 8	28	60	221	170	21	21	M18·M20	3.02
UC10	32	70	274	215	24	25	M22·M24	5.32

## SWIVEL NEW CLAMP

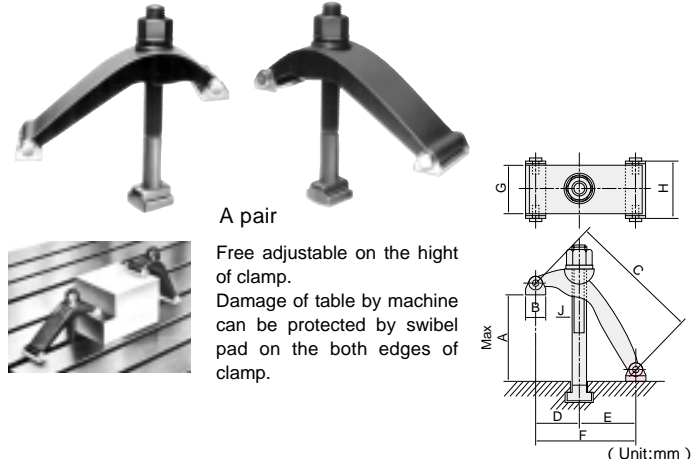

Item No.	A	B	C	D	E	F	G	H	T-slotted bolt J	Flange nut	Weight (kg) (A pair)
NC 50	75	17	114	36.5	47.5	84	42	46.5	TBM 12125	12MFN	1.57
NC 60	85	20	146	32	78	110	49	54.5	TBM 16150	16MFN	2.68
NC 80	105	25	189	48	109	157	55	61.5	TBM 20175	20MFN	4.99

## CLAW CLAMP (for Injection machines)

This product is manufactured and designed as optimal clamp to specially install the molds for injection machines.  
Also it is possible to use as a clamping fitting for press.

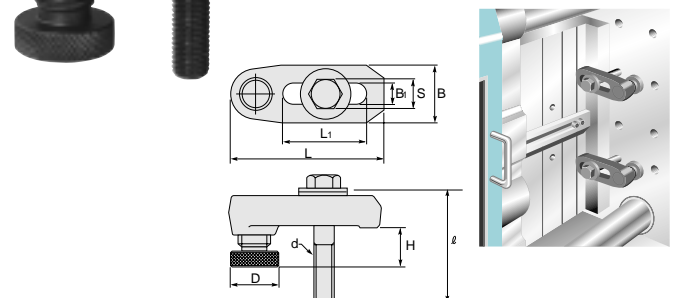

Item No.	d	Stroke H	B	B <sub>1</sub>	D	L	L <sub>1</sub>	ℓ	S	Weight (kg)
FL 12	M12	15 ~ 35	38	13	39	100	48	75	19	0.75
FL 16	M16	18 ~ 42	45	17	39	125	69	90	24	1.10
FL 20	M20	22 ~ 50	56	21	48	160	90	110	30	2.13

## UNI- CLAMP (Duck shaped type)

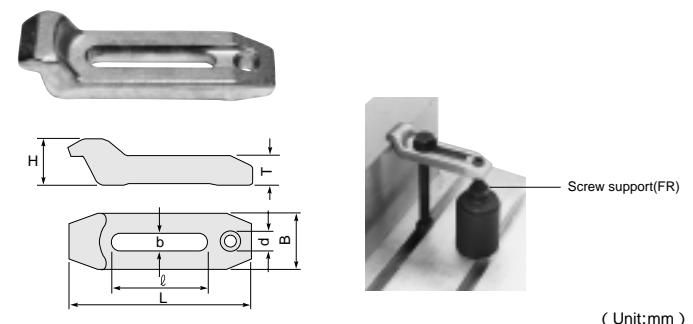

Item No.	b	d	H	T	L	ℓ	B	Applicable bolt	Weight (kg)
FGB 12	13	M12	32	17	125	63	36	M12	0.38
FGB 16	17	M16	40	21	160	80	48	M14·M16	0.88
FGB 20	21	M20	50	26	200	100	59	M18·M20	1.65
FGB 24	26	M24	63	33	250	125	70	M22·M24	2.90