

LATERAL LIFTING CLAMP (Universal shackle type) PAT.

GVC 0.35E ~ 2E

Clamp specifically designed for the lateral (horizontal) lifting of structured steel ("H", "I", "T" and "L" shaped steels, etc.) and steel plates.

(This clamp can be used for clamping "I" beams with 100 mm wide flanges.)

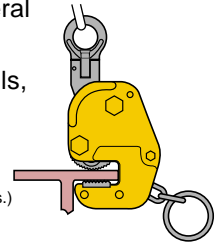

FEATURES

- The universal shackle and shaped pad will provide a stable lateral (horizontal) clamping force.
- The spring-loaded tightening lock mechanism assures a positive initial clamping force.
- The clamping force increases in proportion to the weight of the load.
- The main body and the shackle are made from die-forged special alloy steels, which are optimally tempered for maximum strength and durability.
- High-frequency quenching of die-forged special alloy steels gives greater durability to the cam.
- The main body is a baked-on finished.

SPECIFICATIONS

Item No.	Rated capacity (ton)	Jaw opening (mm)	Weight (kg)	Remarks
GVC 0.35E	0.35	0 ~ 16	1.7	
GVC 0.5E	0.5	0 ~ 20	2.6	
GVC 1E	1	0 ~ 25	4.5	
GVC 2E	2	5 ~ 35	9.0	

EXAMPLES OF USE

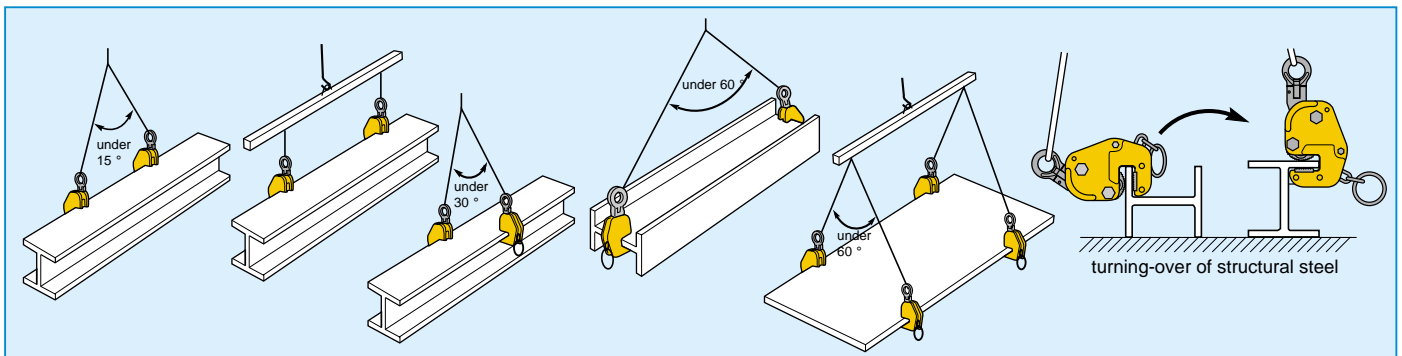

LIFTING CLAMPS FOR STEEL

⚠ Always lift work pieces at 2 or more points for safety.

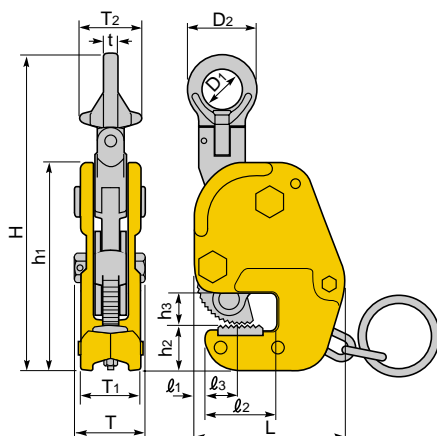

DIMENSIONS TABLE

(Unit:mm)

Item No.	H (MAX)	h ₁	h ₂	h ₃	L	l ₁	l ₂	l ₃	T	T ₁	T ₂	t	D ₁	D ₂
GVC 0.35E	191	120	26	19	87	6	42	21	51	41	39	8	26	45
GVC 0.5E	229	145	34	23	103	6	47	20	55	45	45	10	30	52
GVC 1E	276	183	40	28	130	10	62	26	64	52	53	12	35	60
GVC 2E	343	222	50	38	163	12	70	27	79	63	67	14	45	76