

FEATURES

The spring type tightening lock mechanism assures a positive initial clamping force even under no-load condition.
 The clamping force increases in ratio with the weight of the load.
 The releasing of tightening lock mechanism with remote control avoids the dangerous operation of removing the clamps from the panel at high places. (with 2 meter of rope for remote control)
 One side of the urethane pads with spikes ensures a tight and safe clamping.
 One side with urethane rubber prevents the surface of panels from being damaged.
 Safety hook bolt for the installation of sling belt is attached for extra safety.

Always use this clamp in pair with a balance.



Remote control with a release mechanism

LIFTING CLAMP for ALC panel

PAC 260



Clamp designed for ALC panels

Rated capacity : 260kg/Pce.
 (Two clamps to be used as a pair)

Item No. of set :
 PAC 260FS (for lateral installation)
 PAC 260SS (for vertical installation)

Clamping range is adjustable in 3 phases according to the thickness of the panel.

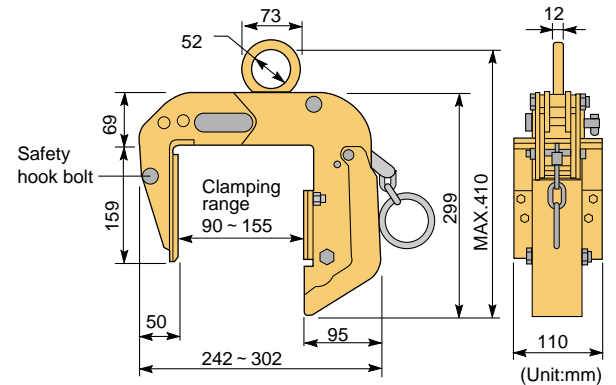

Example of use

Vertical installation

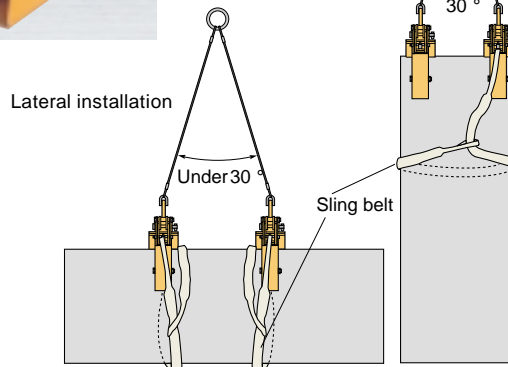

Lateral installation

Sling belt

SPECIFICATIONS

Item No.	Rated capacity (kg)	Applicable range (mm)	Weight (kg)	Remarks
PAC 260	260	90 ~ 105	6.9	
		115 ~ 130		
		140 ~ 155		
PSC 260	260	50 ~ 65	6.9	
		70 ~ 85		

Example of use



LIFTING CLAMP for Molded board PAT.

PSC 260



For extrusion molded board

Rated capacity : 260kg/Pce.
 (Two clamps to be used as a pair)

Item No. of set :
 PSC 260FS (for lateral installation)
 PSC 260SS (for vertical installation)

Optimal for lifting and installation of extrusion molded cement panels.

Clamping range is adjustable in 2 phases according to the thickness of the panel.

