

2-POINT LIFTING BALANCE

Rated capacity: For 500kg, For 600kg
Span : 400, 800, 1000, 2000mm
(with sling belt and shackle)

Item No.	Rated capacity (kg)	Length of span (mm)	Set weight (kg)	Applicable panel lifting clamp	Remarks
PSB 508	500	800	5.2	PSC100·PTC100·150·200·BLC200	
PSB 610	600	1000	6.0	PTC250	
PSB 620	600	2000	7.2	PTC150·200·250·BLC200	
PSB 604F	600	400	3.1	PAC260·PSC260	
PSB 610F	600	1000	8.5	PAC260·PSC260	

Balance designed for well balanced lifting and safety.

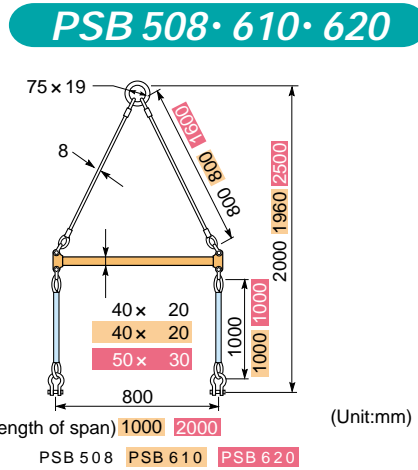

EXAMPLE OF USE

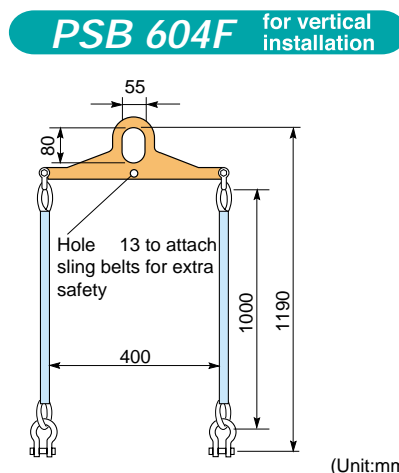

EXAMPLE OF USE



Please use the hook part in PSB604F·610F to attach sling belts for extra safety.

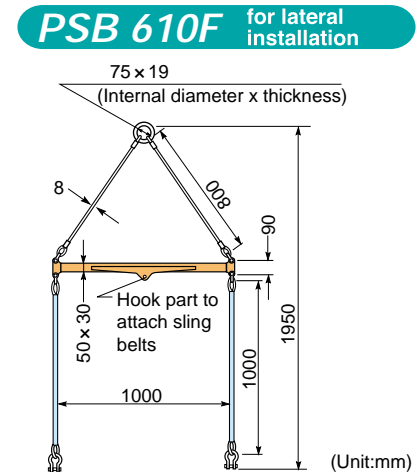

EXAMPLE OF USE



LIFTING CLAMPS FOR HOUSING MATERIALS