



MULTI CRANE



SMC 500H-1000H

Optimal for lifting and moving work at the workshop without crane equipment or at the unreachable high place.

Applications

Maintenance work for vehicles, farm working machinery, machine tools, conveyer lines, etc.
Loading or unloading of goods to or from the vehicles

Feature

The arm length is adjustable at three steps.
Movement of the cranes can easily be made on wheels.
The arm can be hydraulically controlled with ease.
Lifting and lowering of the load can be made by the manual winch.
The Arm and Leg are can be folded to be compact enough to be used anytime and anywhere.

Example of use

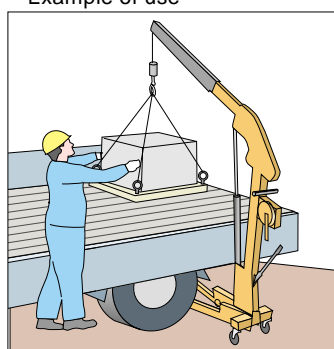

For loading or unloading of goods to or from the truck or light van.

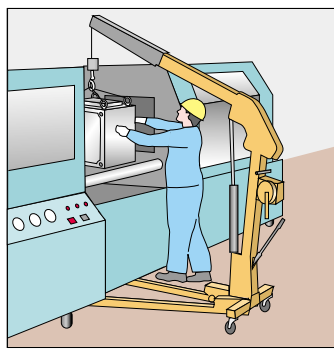

For attachment or detachment of work to or from the machine.

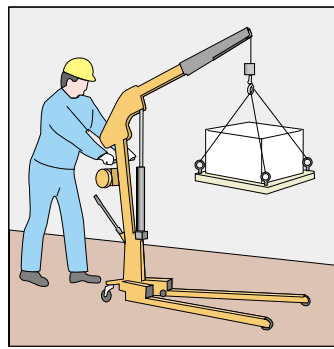

For hand-guiding movement of the crane with the load hanged.

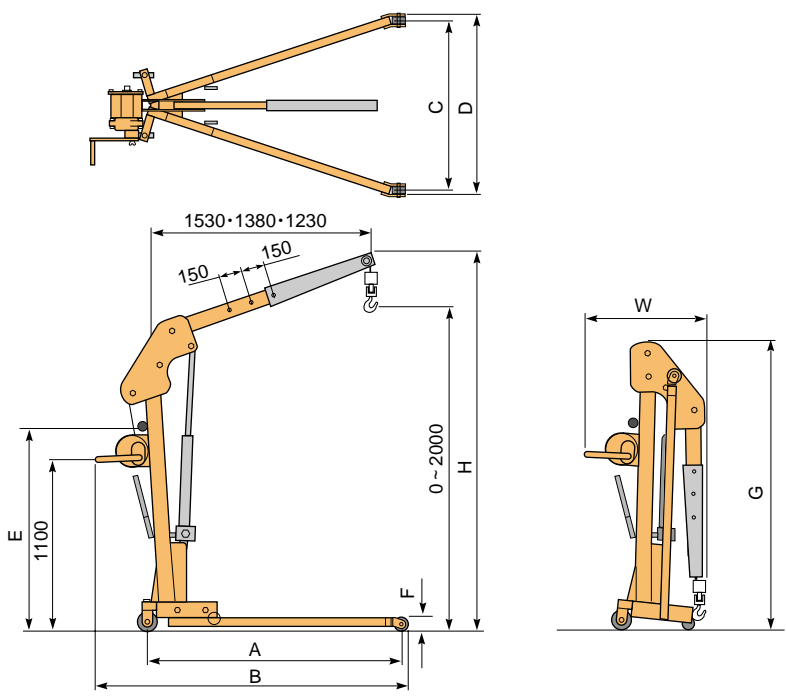

SPECIFICATIONS • DIMENSIONS TABLE

Item No.	Rated capacity (kg)	A	B	C	D	E	F	G	H	W	Weight (kg)	Remarks
SMC 500H	500	1,630	2,000	1,070	1,130	1,300	90	1,825	2,430	750	135	
SMC 1000H	1,000	1,815	2,180	1,090	1,165	1,350	110	1,870	2,450	1,000	200	

(Unit:mm)

CRANES