



FLOOR-FIXED TYPE (Arm H-shaped steel type) (Customized products)

Electric swiveling type/Manual swiveling type

JHC 500K ~ 2800K

Feature

As the arm is made of H-shaped steel, it is optimal for lifting, lowering, and moving heavy work. It is possible to turn the arm for 360 degrees (340 degrees for electric type), which provides a wide range of working area.

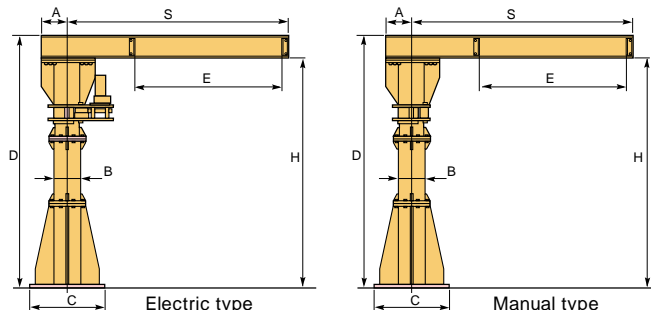

STANDARD SPECIFICATIONS

Item No.	Rated capacity (ton)	Swiveling velocity(r.p.m)	Weight (kg)		Used power(kw)	Swiveling angle(degrees)	
			Electric	Manual		Electric	Manual
JHC 500K	0.5	1	800	700	0.2	340	360
JHC 1000K	1	0.75	1,300	1,200			
JHC 2000K	2	0.5	2,150	2,000	0.4	340	360
JHC 2800K	2.8	0.5	2,750	2,600			

Apart from the specified, conditions are common to electric and manual types.

STANDARD DIMENSIONS

(Unit:mm)

Item No.	Dimensions		Dimensions of I-shaped steel Hight x width x thickness	A		B	C	D	Range of use of E
	S	H		Electric	Manual				
JHC 500K	5,000	3,000	250×150×7.5	500	500	268	1,000	3,250	4,000
JHC 1000K	5,000	3,000	300×150×10	600	600	356	1,400	3,300	4,000
JHC 2000K	5,000	3,000	400×150×10	850	700	407	1,700	3,400	4,000
JHC 2800K	5,000	3,000	450×175×13	850	850	458	2,000	3,450	4,000

You will be separately charged for freight and installation.

FLOOR-FIXED TYPE (Built-in hoist type) (Customized products)

JBC 1526KW ~ 4826KW

Universal-joint type

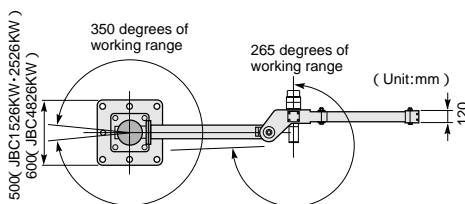

Fixed portion with floor anchor bolts (directly fixed to the floor with anchor bolts)

If the floor slab is stronger than specified, you will be able to freely install the crane at any place of the slab. (Installation is to be made by the user.)

Feature

- The arm has a hoist built in itself, enhancing the lifting height.
- Fixation of the crane on any place of the concrete slab with anchor bolts
- Adaptive to Clean Room specifications
- Flexibility of the whole arm and universal joints secure a wide range of working area.

STANDARD DIMENSIONS

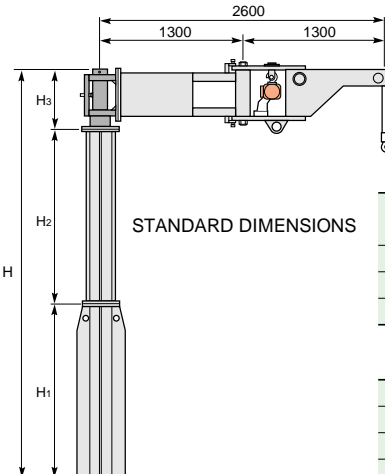

STANDARD SPECIFICATIONS

Item No.	Rated capacity (kg)	Net weight (kg)	Lifting height (m)	Remarks
JBC 1526KW	150	280	3.0	
JBC 2526KW	250	450	3.0	
JBC 4826KW	480	600	3.0	

STANDARD DIMENSIONS

Item No.	H	H1	H2	H3
JBC 1526KW	3,260	1,430	1,430	400
JBC 2526KW	3,250	1,385	1,385	480
JBC 4826KW	3,355	1,400	1,400	555

You will be separately charged for freight and installation.