



JIB CRANE with Electric power chain block



Compact and high power

- Optimal electric chain block for our Crane specifications
- Equipped with a safety mechanism by which to prevent both overloading and overwinding.
- Unique braking mechanism keeps long-term braking power despite strenuous use.
- Two-stepped velocity is available just through the single-phase 100V power source.

Dimensions of electric chain block

(Unit:mm)

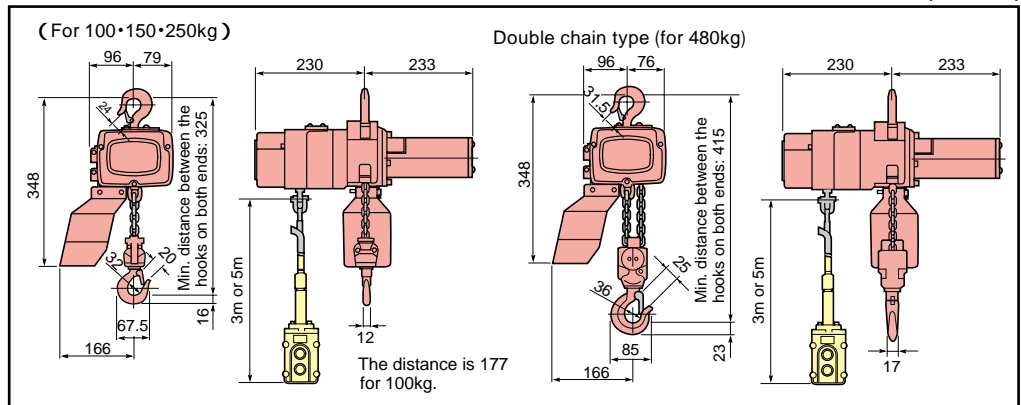

The length of power cord for the chain block is 5m.
The length of the press button cord is 3 or 5m (same as lifting height).

SPECIFICATIONS

Item name./Item No.	Chain block specifications	
	Weight(kg)	Rated capacity (kg) × Lifting height (m)
FLOOR FIXED TYPE		
JBCW 1520K	15.5	150 × 3
JBCW 1530K		
JBCW 1540K		
JBCW 2520K	15.5	250 × 3
JBCW 2530K		
JBCW 2540K		
JBCW 4820K	18.5	480 × 3
JBCW 4830K		
JBCW 4840K		
PILLAR-FIXED/-WELDED TYPE		
JBCW 1520H	17	150 × 5
JBCW 1530H		
JBCW 1540H		
JBCW 2520H	17	250 × 5
JBCW 2530H		
JBCW 2540H		
JBCW 4820H	21	480 × 5
JBCW 4830H		
JBCW 4840H		
PILLAR-FIXED/-BOLTS TYPE		
JBCW 1520HF	17	150 × 5
JBCW 1530HF		
JBCW 1540HF		
JBCW 2520HF	17	250 × 5
JBCW 2530HF		
JBCW 2540HF		
JBCW 4820HF	21	480 × 5
JBCW 4830HF		
JBCW 4840HF		

Item name./Item No.	Chain block specifications	
	Weight(kg)	Rated capacity (kg) × Lifting height (m)
PILLAR FIXED/-COLUMN TYPE		
JBCW 1520HC	17	150 × 5
JBCW 1530HC		
JBCW 1540HC		
JBCW 2520HC	17	250 × 5
JBCW 2530HC		
JBCW 2540HC		
MOVABLE TYPE		
JBCW 1020C	15	100 × 3
JBCW 2020C	15.5	150 × 3
MOVABLE TELESCOPE TYPE		
JBCW 1020N	15	100 × 3
JBCW 2020N	15.5	150 × 3
PILLAR-FIXED/-SIMPLE TYPE		
JBCW 1037H	16.5	100 × 5
JBCW 1521H	17	150 × 5
JBCW 1537H	17	150 × 5
FLOOR-FIXED/-SIMPLE TYPE		
JBCW 1037KH	15	100 × 3
JBCW 1521KH	15.5	150 × 3
JBCW 1537KH	15.5	150 × 3

You will be separately charged for freight and installation.