



Pipe Welding Clamp WOC

Operation Manual

This operation manual explains the basic operation and handling of the clamps. Please read this manual carefully before use and observe the precautions for safe operation.

SUPER TOOL CO., LTD.

For Safety Use

We are thankful to you for your purchase of our External Clamp for Pipe Welding. To enhance safety and efficiency at work, please read this Manual carefully. To fully understand handling procedures and cautions for use, you are kindly asked to make a safe use of this device. Please keep this Manual in a place for your any-time use of it.

Categories of Indications for Warnings

Items of cautions used in this Manual are divided into the following two categories of "WARNING" and "CAUTION".



WARNING

The case in which a wrong use of this tool may cause death or serious injury.



CAUTION

The case in which a wrong use of this tool may cause medium-level or light injury, and physical damage.

Application

- Tool for fixing and centering to process tack welding of pipings.

Features

- Attaching and detaching can be conducted quickly with the fast-forward mechanism.
- Pipes can be fixed and centered by easy operation (fine adjustment is possible).
- The tool can be safely and easily attached and detached and easily carried by the grip.
- As stainless steel is used for the part of the tool that pipes contact it, both iron and stainless steel pipes can be used.

Specifications

Product No.	Applicable pipe		B	W	H	h	L	Weight
	Nominal	External Diameter D						
WOC 6	1~6B	34~170	105	219~335	314~403	255	230	5.2kg
WOC 12	4~12B	110~320		348~525	448~568	322		7.9kg

Parts Names

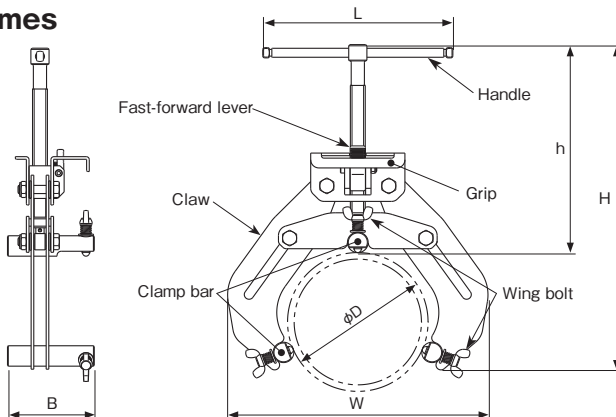

Operational Procedure

- ① Wing bolts are to be loosened (at three points of place). (Fig.1)

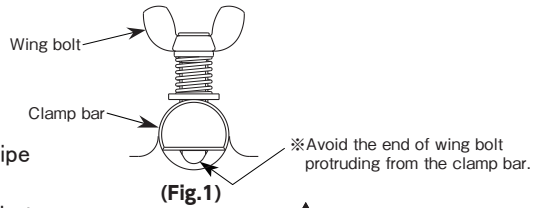

- ② The claw of External Clamp for pipe welding is to be widened. (Fig.3)
Hold the grip and lift up the handle to open the claw by continuously pressing the fast-forward lever (Fig.2).

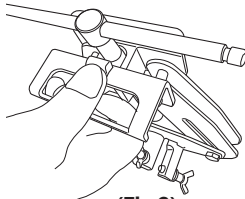

(Fig.2)

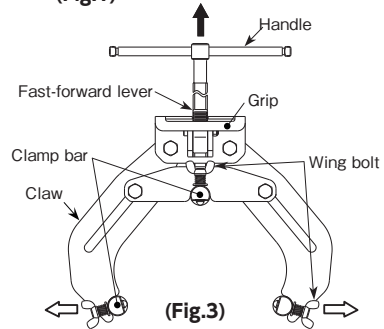

(Fig.3)

⚠ CAUTION

Be careful not to get your fingers pinched during the operation.

- ③ Open the claw of External Pie Welding Clamp, place it at an appropriate position and fix by tightening the handle. (Fig. 4)

※ Here, when you lift up the grip while pressing the fast-forward lever (Fig.5), the claw will close quickly.

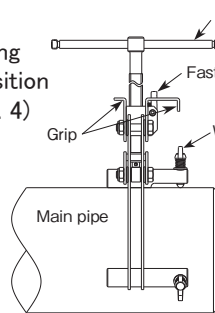

(Fig.4)

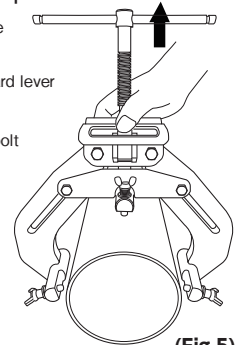

(Fig.5)

⚠ CAUTION

Be careful not to get your fingers pinched during the operation.

- ④ Tighten the wing bolts (at 3 points of place) until the tips of them come into contact with the main pipe. (Fig.6)

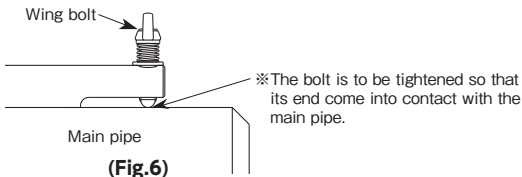

(Fig.6)

- ⑤ Loosen the handle and move the External Clamp for Pipe Welding toward the end of the main pipe, and then, tighten the handle to fix the clamp on the main pipe. (Fig. 7)

- ⑥ Loosen only the upper-side wing bolt (by turning 1 to 2 times).

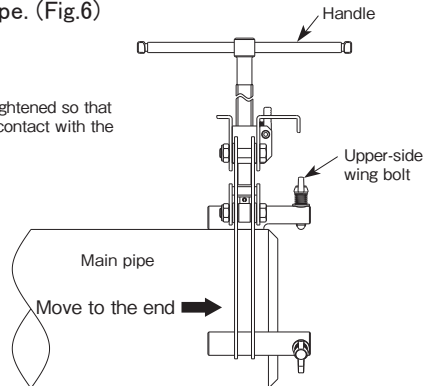

(Fig.7)

⑦ Insert pipe or pipe fitting (elbow, flange, etc.) to be welded between the clamp bars and fix them by tightening the upper-side wing bolt. (Fig. 8)

※ In case the centers are not aligned, further adjustment is to be made by simultaneous use of another wing bolt as well as the already used ones.

※ In case the groove clearance is required, secure the designated clearance, and then, fix the pipe or pipe fitting.



WARNING

The other end of the pipe or the pipe fitting to be welded is to be placed on a supporting table or base.

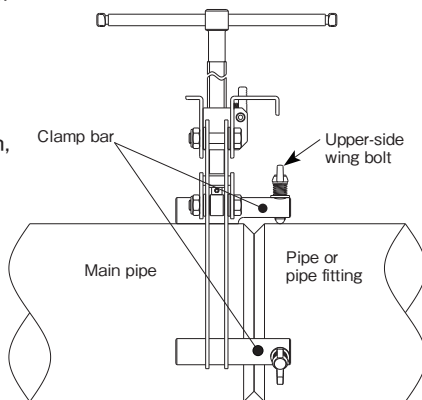

(Fig.8)

⑧ The pipe or the pipe fitting is to be tack welded.

⑨ Detach the external clamp for pipe welding.

Hold the grip and loosen the handle, and lift up the handle while pressing the fast-forward lever (Fig.2). Then, the claw will open quickly.

※ First-forward lever cannot be operated with the handled tightened.



CAUTION

Be careful not to get your fingers pinched during the operation.



WARNING

- Never fail to check for abnormality with any parts of the tool before use.
- Hold the grip in operation in order not to have your fingers pinched during its operation or movement.
- Don't put the total weight of pipe or pipe fitting (elbow, flange, etc.) on the external clamp for pipe welding. They are to be supported by a pipe receiving support or a hanger.
- This Product is a tool for fixing and center alignment of pipes, so never use this for other purposes such as lifting, transportation, correction, etc.
- Don't give impact to this tool by dropping it or hitting it against other things.
- Don't remodel this tool. Heating or processing it will make a significant degradation of its quality (strength).