

» Easy Tightening for Hanging Operation

SSC-N

SCREW CAM CLAMP (Single Eye Type) PAT.

CHECK!



Operation manual & parts drawing

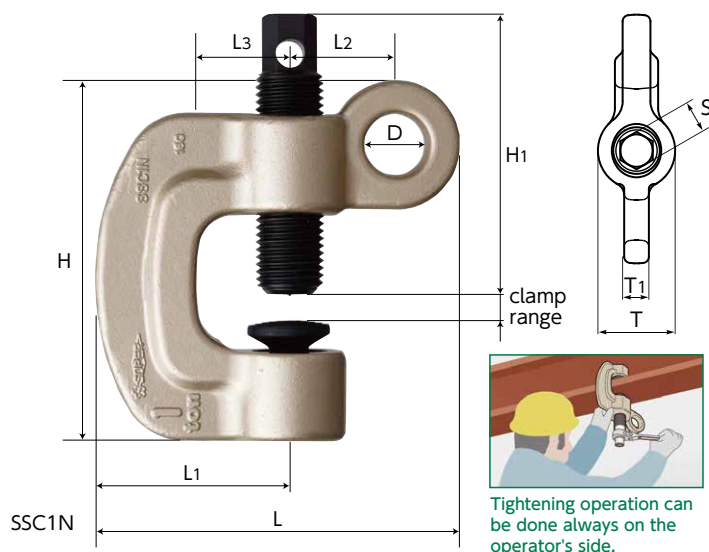

Example of use

⚠ Always lift a load at 2 or more points for safety.

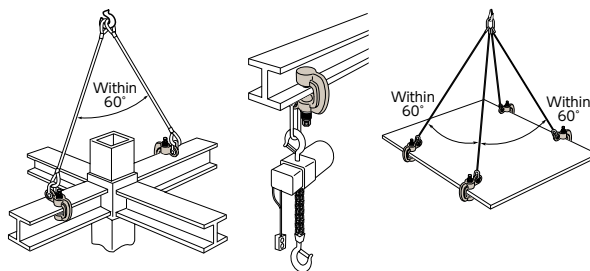

Accessories

- 17x21 Double Size Ratchet Wrench (Short Type)

Features

- Ideal clamp for lifting up and down, and especially suitable as lifting piece for chain blocks or hoists.
- When used in horizontal lifting, the screw is placed on top (operator's side), so the tightening operation can be done easily (when installing underneath a beam, the tightening can be done on the operator's side).
- The circular cam has a mechanism with a spring making it always return to its original position.

Item No.	Rated capacity (ton)	Clamp range (mm)	Size (mm)										N.W. (kg)
			L	L1	L2	L3	H	H1	D	T	T1	S	
SSC0.5N	0.5	0~25	129.5	68	39	30	122	89	22	46	16	21	1.8
SSC1N	1	0~40	161	88	45	40	156	121	26	50	18	21	3.2
SSC2N	2	0~40	186	100	53	40	170	121	32	60	28	21	5.0

Note : For the torque value of the screw tightening, operate tightening over 25N·m (approx. 250kgf·cm).

» Universal Shackle Type

SUC

SCREW CAM CLAMP PAT.

CHECK!



Operation manual & parts drawing

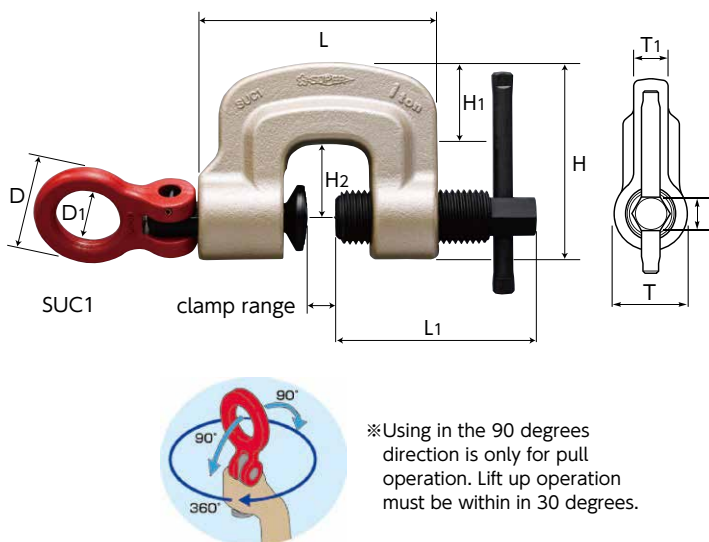

Example of use

⚠ Always lift a load at 2 or more points for safety.

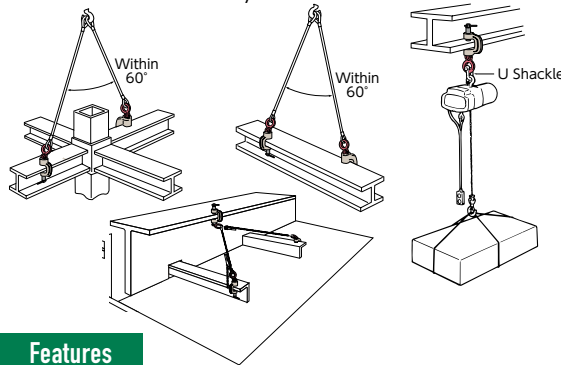

Features

- The shackle turns at 360° in all lifting or pulling directions, enabling a stable lifting angle and a wide range for pulling operations.
- The screw and the circular cam provide sure clamping force.
- The cam tilts and the clamping force increases in proportion to the load weight in the lateral direction.
- The circular cam has a mechanism with a spring making it always return to its original position.

Applications

- Ideal for lifting, horizontal pulling and turning-over of steel plates and steel beams in industries like civil engineering, construction, shipbuilding, can manufacturing industry.
- Also most suitable as light-weight and compact type for lifting down chain blocks or hoists as a jig, or horizontally pulling structural steel.

Item No.	Rated capacity (ton)	Clamp range (mm)	Size (mm)										N.W. (kg)	
			L	L1	H	H1	H2	D	D1	T	T1	S		
SUC0.5	0.5	0~25	119.5	89	91	38	30		60	35	46	22	21	2.4
SUC1	1	0~30	129.5	109	108	45	40		75	45	50	26	21	3.7
SUC1.6	1.6	0~30	132.5	136	110	55	45		80	50	60	30	21	6.0
SUC3.2	3.2	0~40	165	136	130	55	45		80	50	60	30	21	6.0

Note : For the torque value of the screw tightening, operate tightening over 25N·m (approx. 250kgf·cm).

★ Parts drawings and operation manuals can be downloaded from our website.  
● For all the appendix, please refer to P.54 ~56



Vertical & lateral lifting clamps  
Vertical lifting clamps  
Lateral lifting clamps  
Horizontal lateral lifting clamps, lifting hooks  
Steel beam lifting clamps, balance  
Screw cam clamps  
Beam clamps  
Super foot locks, lifting hooks  
Super lock hooks  
Drum lift clamps  
Lifting hooks for forklift, rail clamps  
Reinforcing rod vertical lifting clamps  
safety belt clamps