

» Stable Lifting for Drums

**DLC0.5V**

**DRUM LIFT CLAMP (Vertical Lifting)**

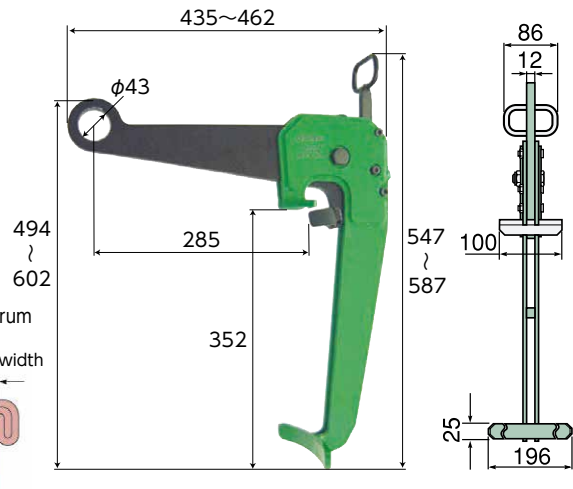

**Example of use**

⚠ You cannot lift a drum can with no lid. Don't use for turning over a drum can.

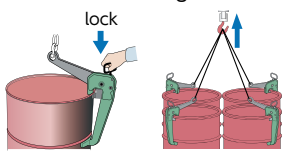

**Features**

- Clamp dedicated to vertical lifting of drum cans.
- Easy operation with firm locking (by wedge method).
- You can safely lift a drum can vertically.
- Easy to lock by pushing and pulling the handle.
- The lifting ring diameter is large enough to be hooked directly.

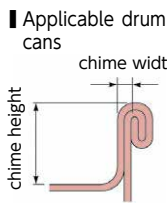

Applicable drum cans  
JIS Z1601 type : H class and M class (with 600mmφ lid) and drum cans with lid of 500 to 700mm in diameter, with chime thickness of 2 to 3.5mm and chime height of 22 to 28mm (lifting is vertical only for 600mmφ lid).

Item No.	Rated capacity (ton)	Clamp range (mm)	N.W. (kg)
<b>DLC0.5V</b>	0.5	Chime width: 2~3.5, Chime height: 22~28	9

Vertical & lateral lifting clamps

Vertical lifting clamps

Lateral lifting clamps

» Easy Operation for Open Drum

**DLC0.5**

**DRUM LIFT CLAMP**

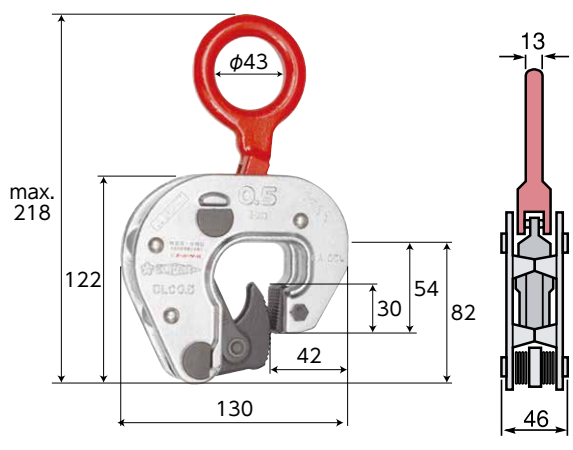

**Features**

- Clamp dedicated to lifting drum cans.
- Easy lifting of steel drums and drums without lid by one touch grip of the chime.
- Drum cans can be easily lifted vertically and turned over.

**Applicable drum can**

Chime height over 25mm and  
Drum conforming to JIS Z1600 H class or M class  
Drum conforming to JIS Z1601 H class or M class

**Example of use**

⚠ You cannot lift a drum can with no chime. Do not lift 5 or more drum cans for safety.

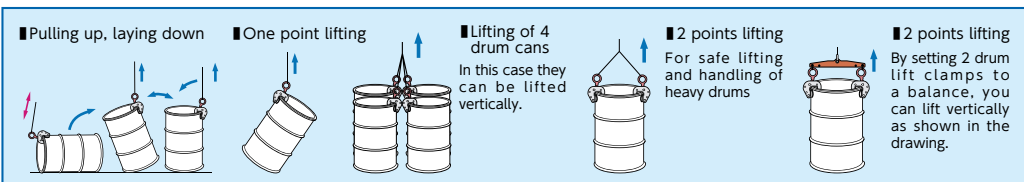

**Cam, pad : line type**



Item No.	Rated capacity (ton)	N.W. (kg)
<b>DLC0.5</b>	0.5	2

Horizontal lateral lifting clamps, lifting hooks

Steel beam lifting clamps, balance

Screw cam clamps

Beam clamps

Super foot locks, lifting hooks

Super lock hooks

Drum lift clamps

» Adjustable Span Type

**DSB1S**

**BALANCE FOR DRUM LIFT CLAMP**

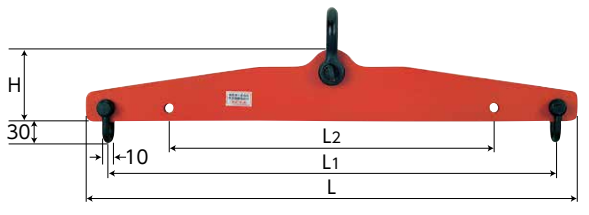

**Features**

- Balance dedicated to drum lift clamp (DLC0.5).
- Lifting width between 2 points (L1, L2).

Item No.	Rated capacity (ton)	Size (mm)				N.W. (kg)
		L	L1	L2	H	
<b>DSB1S</b>	1	675	615	445	100	6

Lifting hooks for forklift, rail clamps

Reinforcing rod vertical lifting clamps

safety belt clamps

\* Parts drawings and operation manuals can be downloaded from our website.  
● For all the appendix, please refer to P.54 ~56